

# Laminate Flooring wineo 500/700 to Click



The **wineo 500/700 laminate flooring** is a high-quality, multi-layer flooring with a hard-wearing melamine resin top layer in various specifications. For more information, please refer to the technical data in our product collections.

## **Important general information**

Always store wineo 500/700 laminate flooring in a dry place. The film is not a substitute for a dry storage location and does not provide permanent protection against moisture.

Before processing, make sure that the delivered goods are in perfect condition. Goods that have been cut to size or laid are not subject to complaint. Before installation, the goods must be checked for color and batch uniformity. Only install planks of the same batch in the same room. The relevant national standards, guidelines and regulations as well as the technical references and recognized rules of the trade apply to the installation of wineo 500/700 laminate flooring.

In Germany, the following guidelines in particular must be observed:

- VOB Part C, DIN 18365 Floor covering work.
- DIN 18560 Minimum requirements for screeds Part 1H

**Note:** Accelerated screeds and screeds with admixtures are considered "special constructions". Any deviations from the specifications in DIN 18560 (Screeds in Construction - Part 1) with regard to the readiness of the screed for covering must be communicated by the client. Deviating from DIN 18560, we recommend a maximum residual moisture  $\leq 0.3\%$  CM for CA heated screed.

- BEB leaflet: "Assessment and preparation of substrates, installation of resilient and textile floor coverings".
- - DIN 18202 "Tolerances in building construction".
- - Sanitär Heizung Klima ZV Code of Practice: "Interface coordination for heated floor constructions".

## **Substrate condition**

Prepare the substrate in accordance with VOB Part C Floor Covering Work DIN 18365. The substrate must be level, load-bearing and permanently dry. The maximum height tolerance must not be exceeded in accordance with DIN 18202 "Tolerances in building construction - Table 3, line 4", 3mm per linear meter or, in the case of tile edges, 1mm per 10cm.

## **Substrates**

wineo 500/700 laminate flooring can be laid floating on all types of screed, on existing vibration-free wood, plank and chipboard flooring, on PVC, plastic coverings and linoleum, on stone, ceramic and marble floors. Textile floor coverings and needlefelt must be removed. Generally, the removal of old floor coverings is recommended to counteract interactions and irritations. To level out unevenness, the application of a suitable leveling compound is recommended. Please observe the instructions of the building material suppliers. Substrates not listed require approval by Windmüller GmbH.

**Note:** The flooring installer shall raise concerns during his inspection prior to installation of the flooring.

In particular in the case of:

- major unevenness,
- cracks in the subfloor,
- insufficiently dry subfloor,
- insufficiently firm, too porous and too rough surface of the subfloor,
- contaminated surface of the substrate, e.g. by oil, wax, varnish, paint residues,
- incorrect height of the surface of the substrate in relation to the height of adjacent components,
- unsuitable temperature of the substrate,
- unsuitable room climate,
- missing heating protocol in case of heated floor constructions,
- missing protrusion of the edge insulation strip,
- missing marking of measuring points in case of heated floor constructions
- missing joint plan

(Source: commentary on DIN 18365 floor covering works).

# Laminate Flooring wineo 500/700 to Click



## Underfloor heating:

When laying laminate flooring, EN 1264-2 (underfloor heating systems and components) must be taken into account in addition to VOB DIN 18365. The surface temperature should not exceed 27°C permanently. If other underfloor heating systems are used, please consult the Windmüller GmbH application engineering department.

## Tools for laying (1):

- Folding rule / measuring tape
- Spacer
- Pencil / parallel tracer
- Angle
- Punch / jigsaw



## Acclimatization (2):

The wineo 500/700 laminate flooring must be acclimatized lying down for at least 24-48 hours before installation, unopened in small stacks of max. 2 packages, in the rooms to be installed or adjacent rooms under the following conditions!



## Room climatic conditions:

- Air temperature in the room > 18°C (but not more than 26°C)
- Floor temperature > 15°C (but not more than 25°C)
- Relative humidity should be between 50% and max. 65%.

On mineral subfloors, a vapor retarder (3) in the form of a PE film with an SD value  $\geq 75\text{m}$  is required. The vapor retarder is laid out below the intermediate layer. The overlaps are to be connected with a suitable sealing tape in a moisture-barrier manner. In the case of rooms without basements, vaulted ceilings or passageways, suitable structural waterproofing must be provided in accordance with DIN 18195/18531-35. This also applies to installations above rooms with particularly high humidity or for installations directly on concrete.



# Laminate Flooring wineo 500/700 to Click



## Acoustic/impact sound underlayment

Depending on the existing subfloor, underlays can have a decisive influence on living comfort. For wineo 500/700, we recommend the use of an original wineo acoustic/impact sound carpet pad, such as soundPROTECT or soundPROTECT profi. Insulation underlays reduce sound transmission to other rooms, reduce footfall noise and thus significantly improve living comfort. The CS value (compressive strength) of insulation underlays should be at least  $\geq 90$  kPA.

## Installation of wineo 500/700 laminate flooring

Movement joint / edge distances:

Movement joint: at least 10mm width.

Tip: Use leftover pieces of the flooring as spacers. Also observe a distance of 10mm to all fixed objects in the room, such as pipe ducts, door frames, etc.! This movement joint must not be covered with silicone, electric cables or similar!

## Installation

Lay the panels with the front side facing the main light source of the room. You can significantly improve the inherent stability of the installed floor by laying long, narrow rooms lengthwise. Always work from right to left in the installation area (4). Laying: When doing this, the tongue sides of the panels face the wall. Make sure that the head joints with tongue and groove fit exactly over each other and lock them with light pressure from above until the head sides fit exactly in front of each other (5).

Now mark the element to be inserted at the end of the room and cut (6) it to fit exactly. Make sure that an edge distance of at least 10mm is guaranteed and insert the element as described above (7).

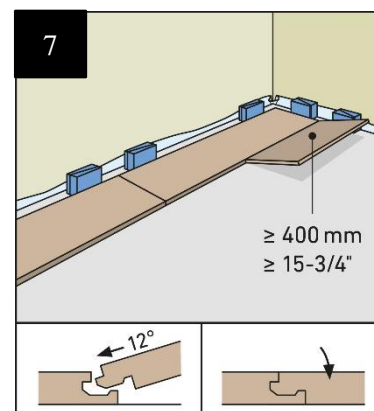
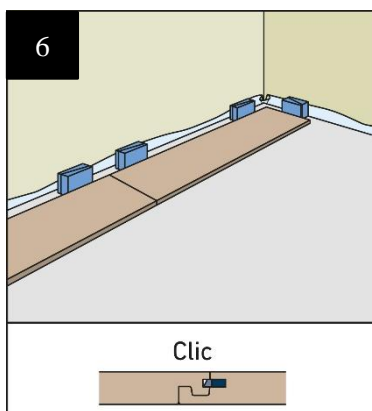
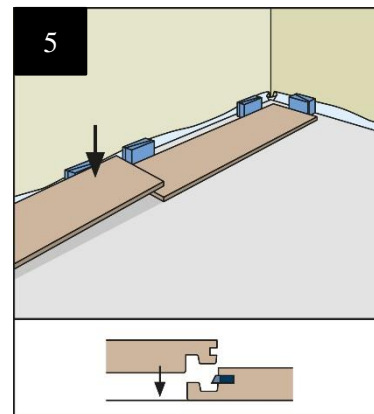
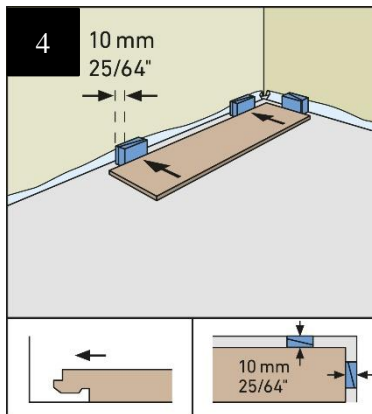

# Laminate Flooring wineo 500/700 to Click



To lay the subsequent rows, place the remaining panel of the first row, at least 40cm long, in the longitudinal groove of the row already lying flat at an angle of approx. 12° and lower it against the front row with slight pressure (8). Take the following panel, guide it at an angle of also 12° lengthwise into the panel of the first row already lying flat on the floor, guiding it as close as possible to the head side of the previously laid panel (9) and lock it as described above (10).

This technique is used to lay all the remaining rows.

To lay the last row, measure the distance between the wall and the laid row and transfer it to the panel (11). The last laying row should correspond to half a panel width if possible. Remember the 10mm wide movement joint.

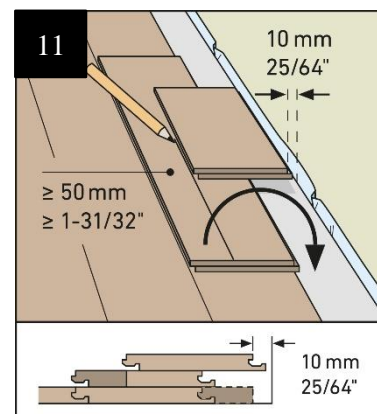
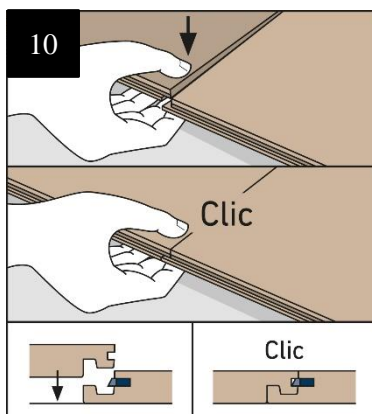
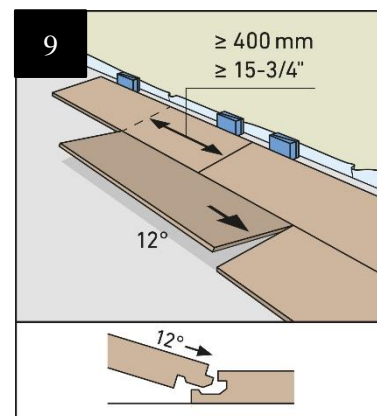
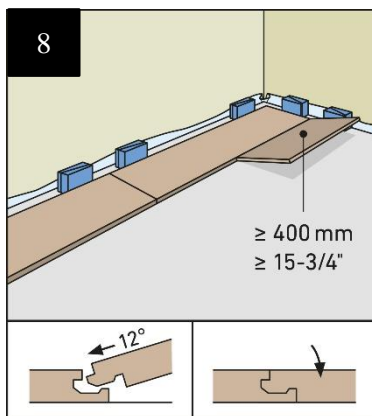

## Movement profiles in the surface

Rooms with an uninterrupted area of 100m<sup>2</sup> can be laid without joints, taking into account the double edge distance (approx. 10mm). A side length of approx. 12m lengthwise and 8m crosswise to the panel should not be exceeded. Suitable movement profiles should be used for very narrow, long rooms. Room areas that are interrupted by rising building components (pillars, partition walls, doorways, etc.) should be separated by placing movement joints (at least 10mm, depending on the size of the area) at the height of the building components.

When installing skirting boards, transition or end profiles, it must be taken into account that the skirting boards or profiles must never be fastened to the floor covering!

# Laminate Flooring wineo 500/700 to Click



## Important notes on finishing the installation

- Remove all spacers
- Seal movement joints/pipe penetrations etc. with profiles/rosettes or with a suitable filling cord and seal joint sealant.
- Laminate flooring must not be fixed on site at any time. The floor covering must not be fixed to the subfloor or to or by furniture or other fixed installation parts.

## Special features and exceptional situations

- In conservatories or similar rooms with large areas of overhead glazing, the use of wineo 500/700 laminate flooring should be regarded as critical due to extreme fluctuations in the room climate.
- requires separate coordination and approval by Windmüller GmbH.
- When using permanently elastic sealants, first fill the joint areas with a joint sealing tape (see accessories, part no. 20080300). Now close the joint with silicone compound so that a two-flank adhesion is created.
- is created. Permanently elastically sealed joints are to be regarded as maintenance joints and must be regularly checked and, if necessary, renewed.
- In order to prevent material changes/damage, sufficient shade must be provided when laying in areas with strong sunlight.
- sufficient shading must be provided.
- At fireplaces and tiled stoves, an adequately dimensioned "radiation barrier" (e.g. glass or (e.g. glass or metal floor panels). The size varies depending on the heating capacity of the fireplace or tiled stove.
- Please observe the specifications of your stove builder / chimney sweep here.
- In the case of furnishings with a high static pressure load, sufficient load distribution (e.g. sufficient load distribution (e.g. load distribution plates) must be provided according to the weight.

Please note that the contractor has a maintenance obligation (protection of the floor covering from damage by subsequent trades) for a completed but not yet accepted trade.

Through partial acceptance, the maintenance obligation for the accepted areas is transferred to the client.

## Cleaning and maintenance

Please refer to our detailed cleaning and detergent recommendations at [www.wineo.de](http://www.wineo.de)!

These instructions do not claim to be complete.

With the publication of these installation instructions (as of 03/2023), all previous versions lose their validity.